

# ASSEMBLY INSTRUCTIONS

This instruction applies to the following items:

VA48、VA60SD

Step 1

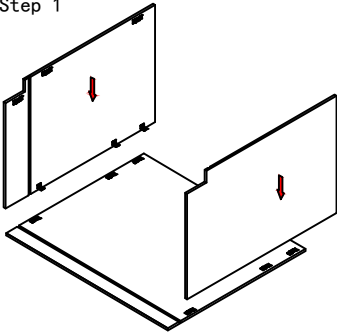

Step 2

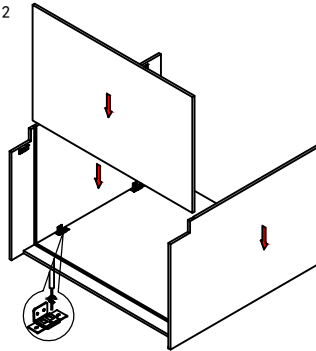

Step 3

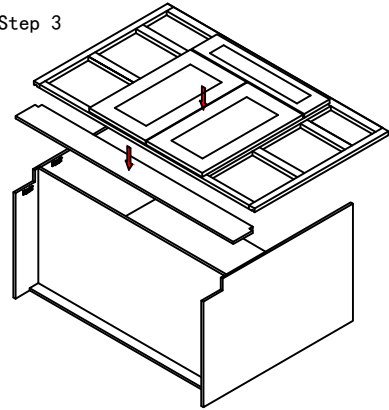

Step 4

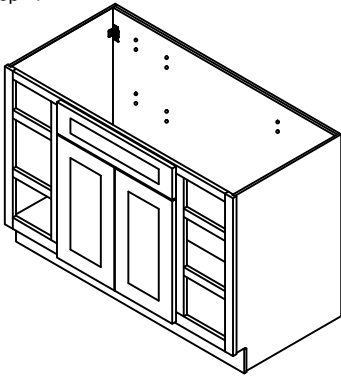

Step 5

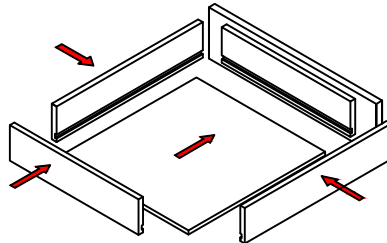

Step 6

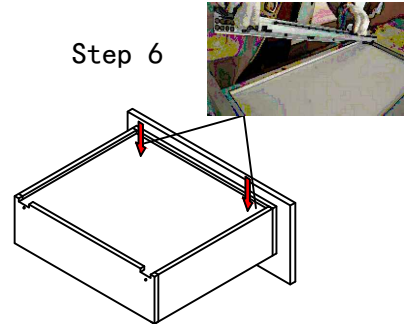

Step 7

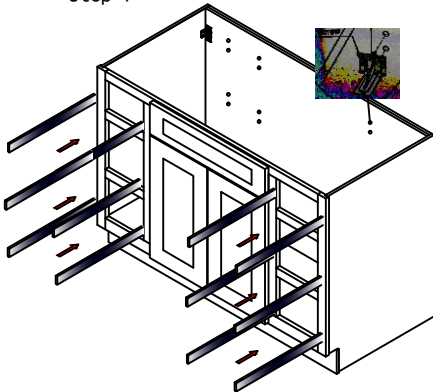

Step 8

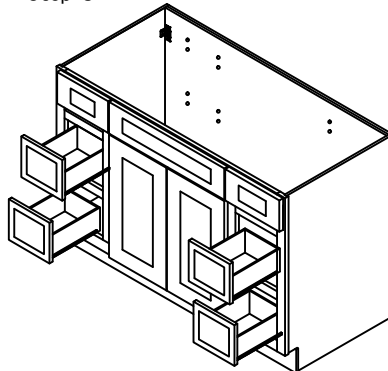

Step 9

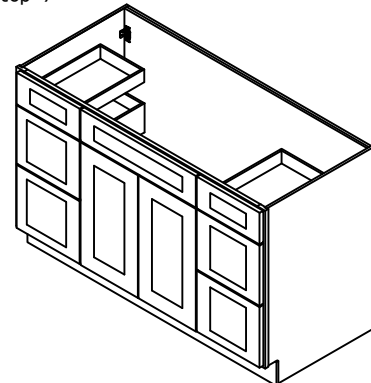

Description	Description
φ 3.5*12 SCREW	FOR SCREWING CLEAT AND BUCKLE
φ 3.5*16 SCREW	FOR SCREWING HINGE AND DOOR
φ 3.5*19 SCREW	FOR SCREWING HINGE AND FRAME, AND CORNER BLOCK
φ 3.5*25 SCREW	FOR SCREWING SIDE PANEL/BACK PANEL
φ 3.5*30 SCREW	FOR SCREWING THE SIDE PANEL/BACK PANEL TO THE TOP/BOTTOM PANEL